

Instrução de montagem
 Instrucciones de montaje
 Fitting instructions
 Instructions de montage

DESIGN SUZANA NOBRE
NEW W&C CARE
 sanindusa®

SANINDUSA, S.A
 Zona Industrial Aveiro Sul
 Costa do Valado, Ap.43
 3811-555 Aveiro
 tel. +351 234 940 250
 fax +351 234 940 266
 sanindusa@sanindusa.pt
 www.sanindusa.pt

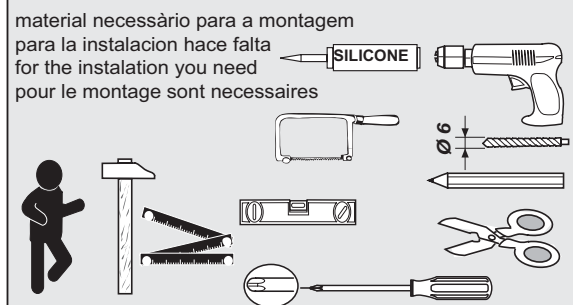

CONJUNTO DE PEÇAS • CONJUNTO DE LAS PIEZAS • PARTS SUPPLIED • PIECES CONSTITUTIVES

(J)	(L) N.2	(M) N.1
	(N) N.2 4.8X9.5	(O) N.1
	(P) N.3 6X40	(Q) N.1
	(R) N.3	(S) N.1+1
(T) N°1		

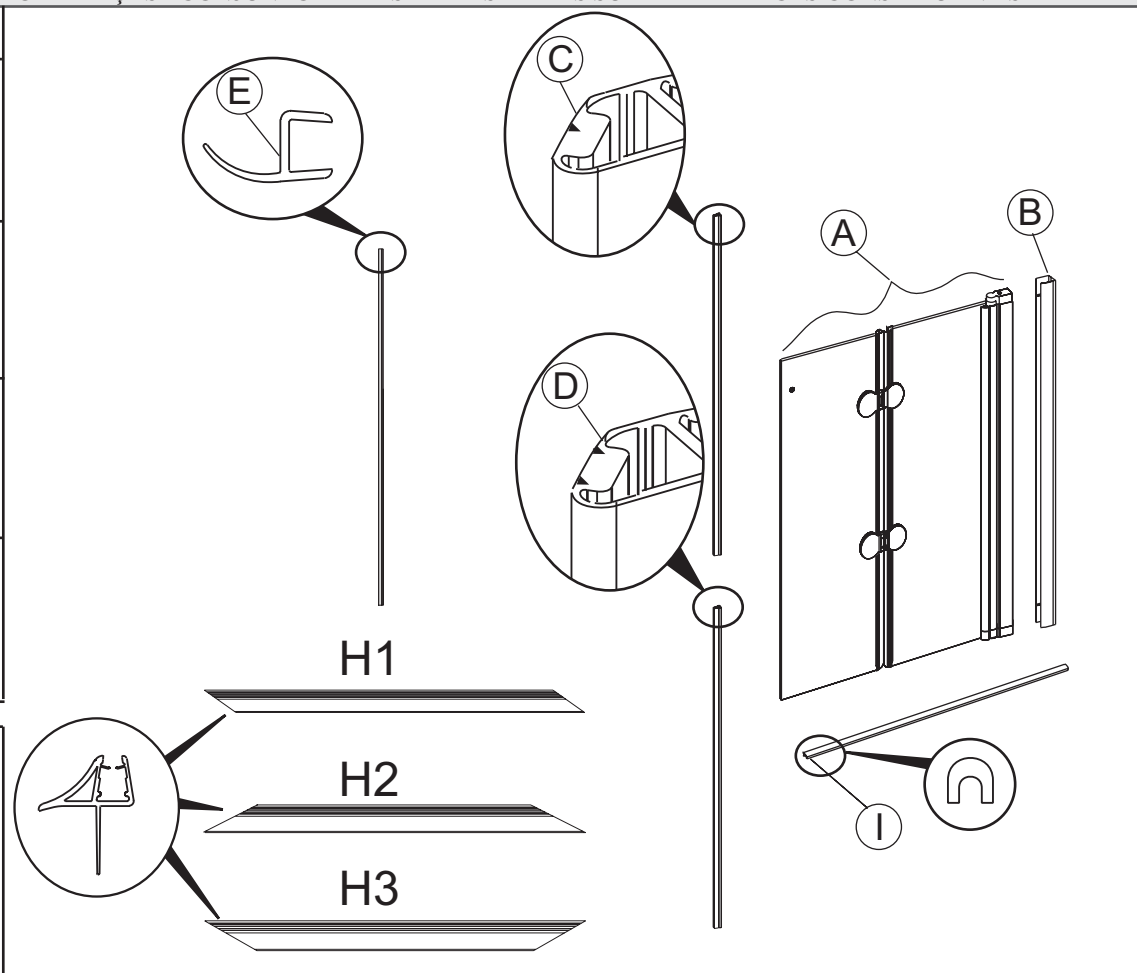

angulo / angulo / corner / à angle

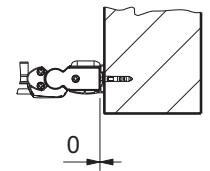
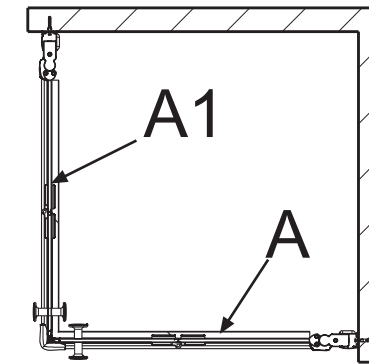

entre paredes / entre paredes /
 in line / en niche

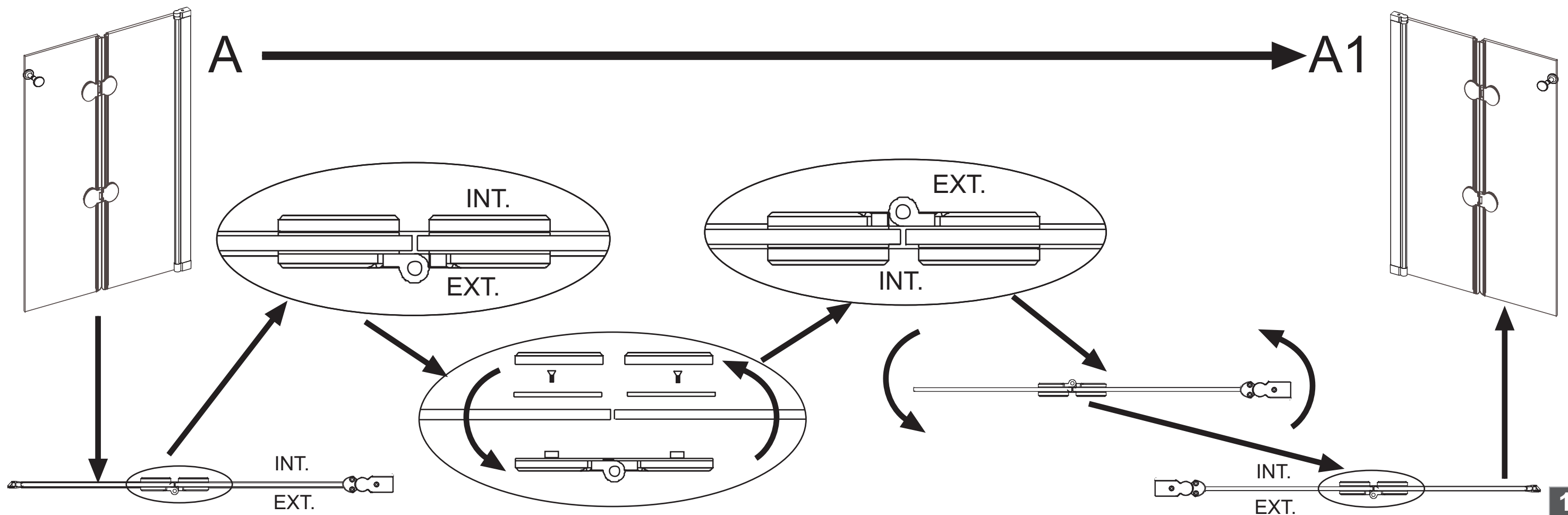
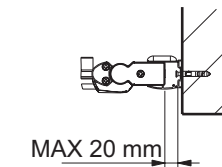
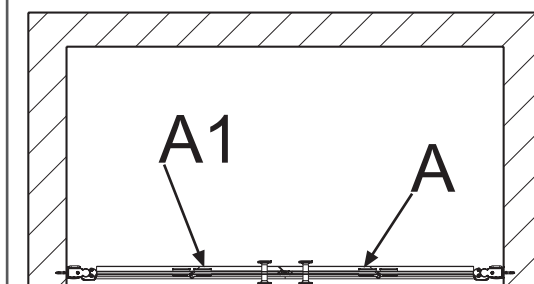

Montagem dos vedantes em ângulo / Montaje Gomas Angulo /
Seals For Corner Fitting / Assemblage Joints Angle

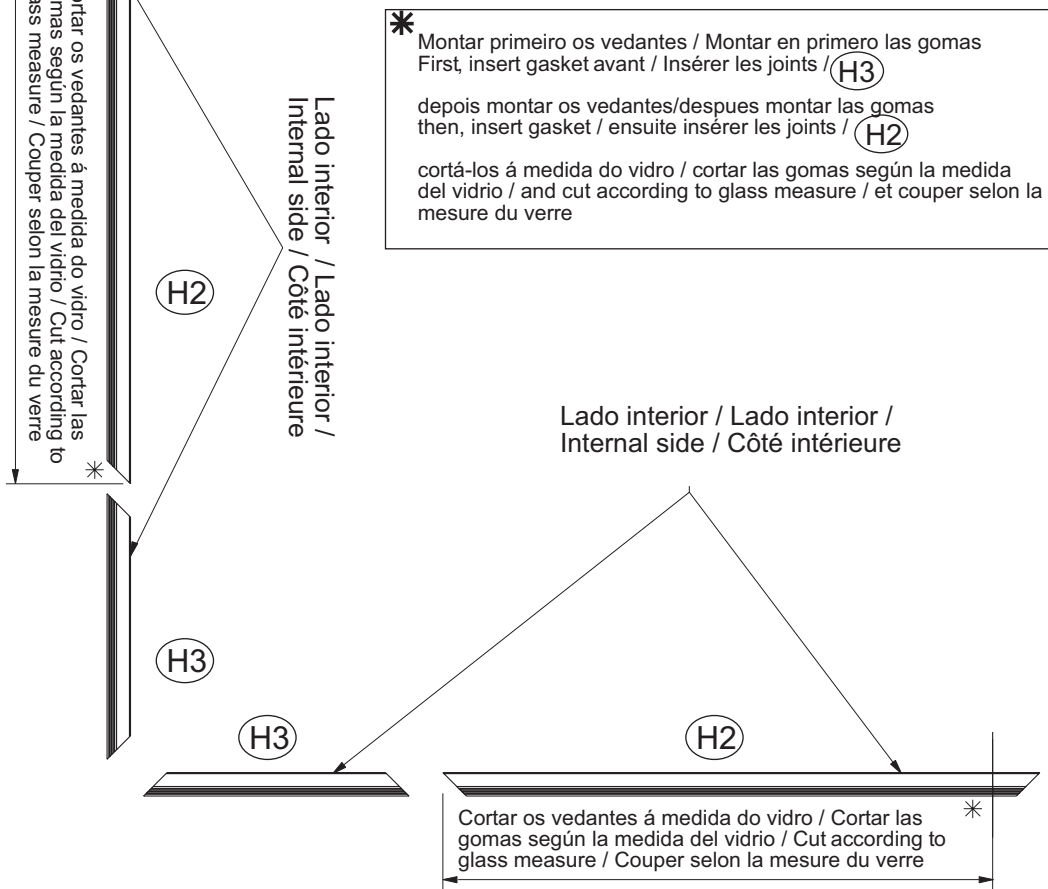

2

Montagem dos vedantes entre paredes / Montaje gomas entre paredes /
Seals for in line fitting / Assemblage joints en niche

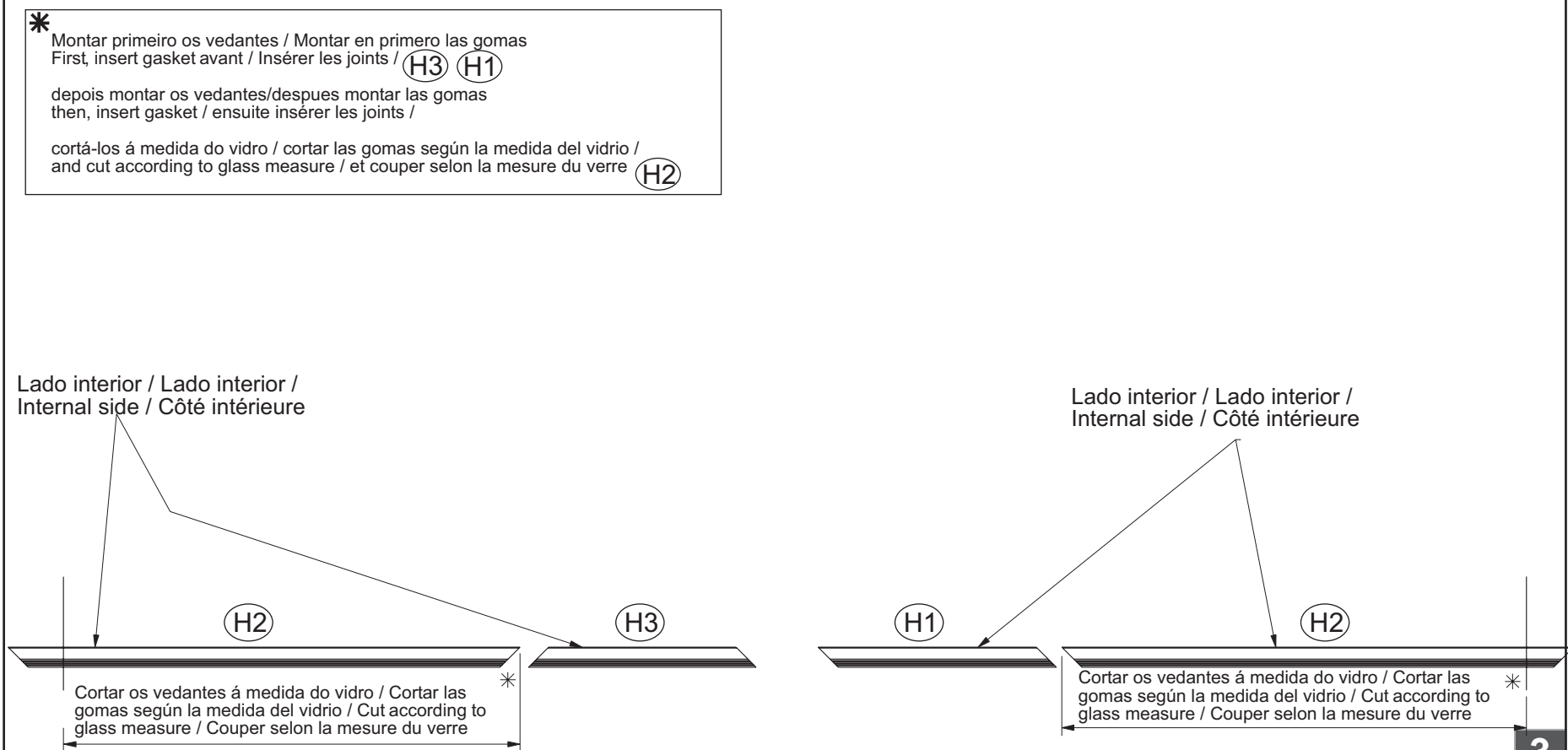

3

angulo / angulo /
corner / à angle

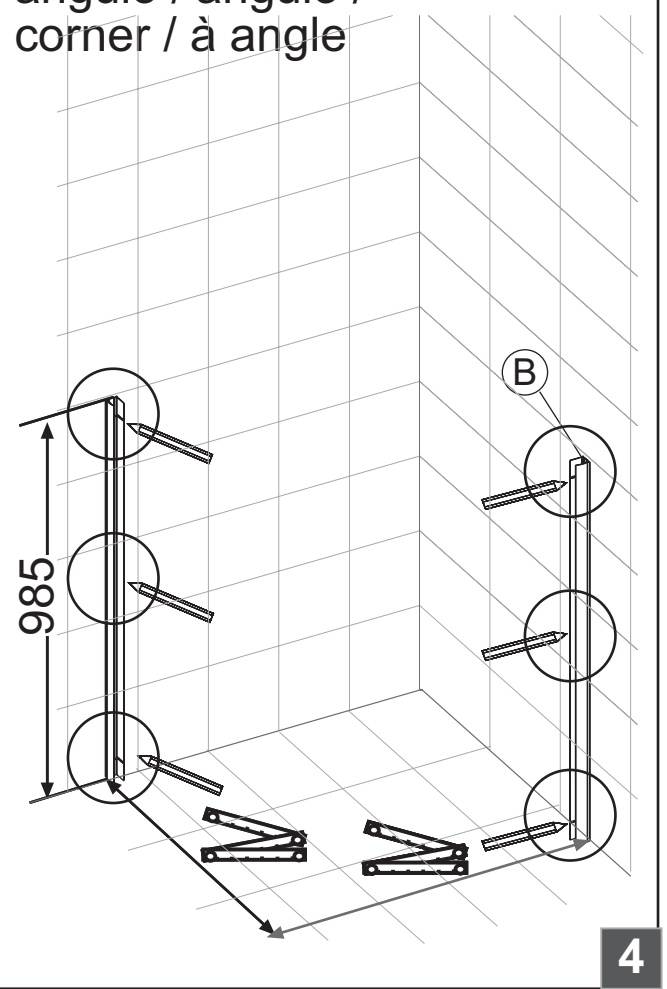

4

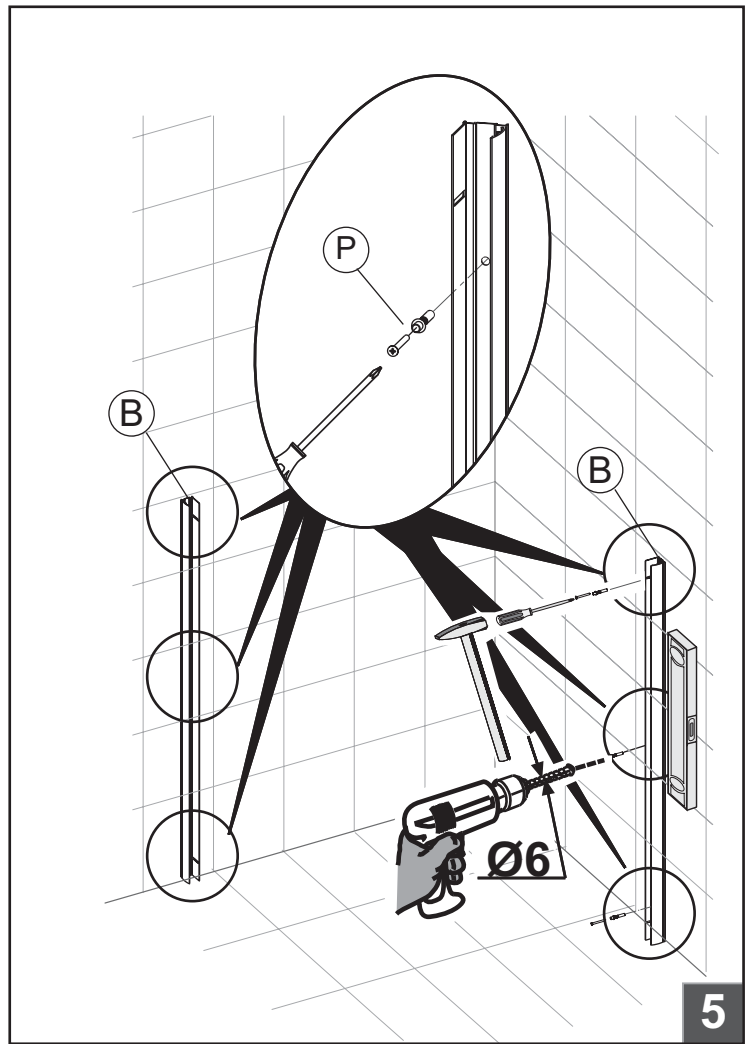

5

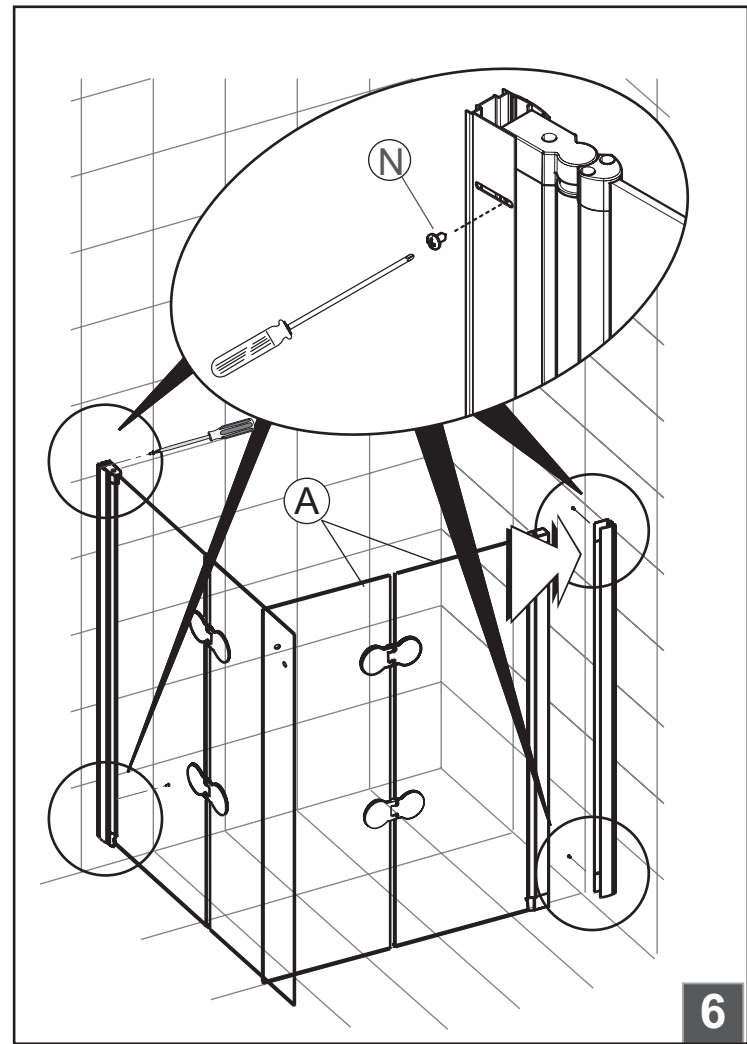

6

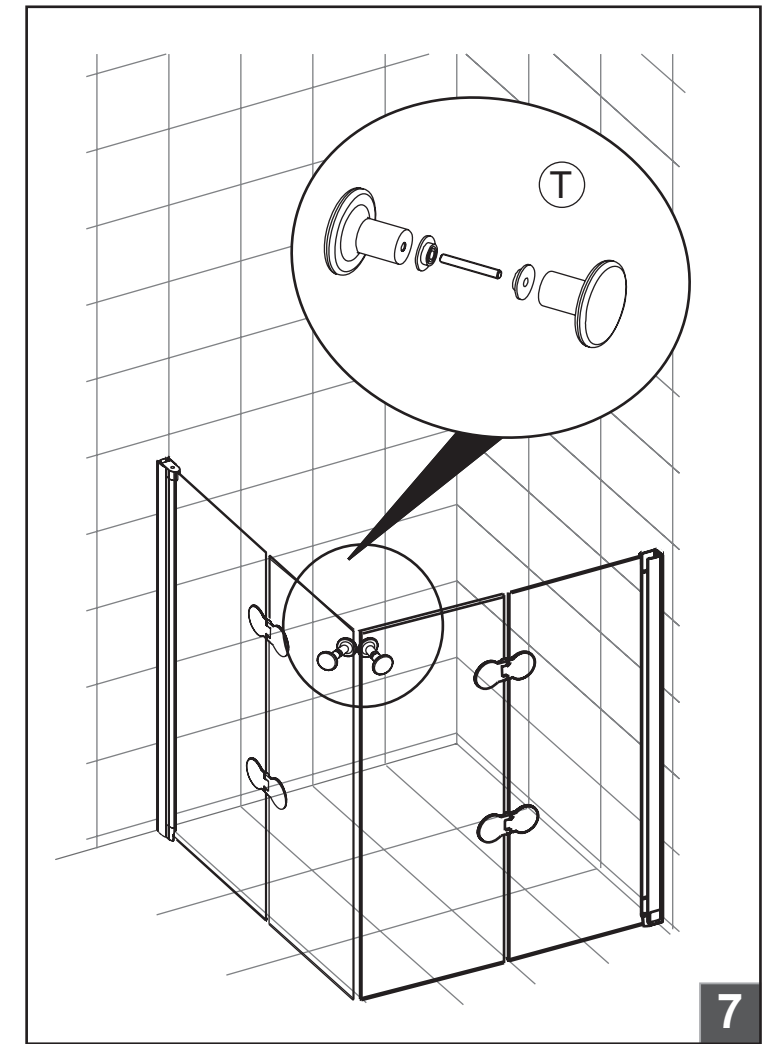

7

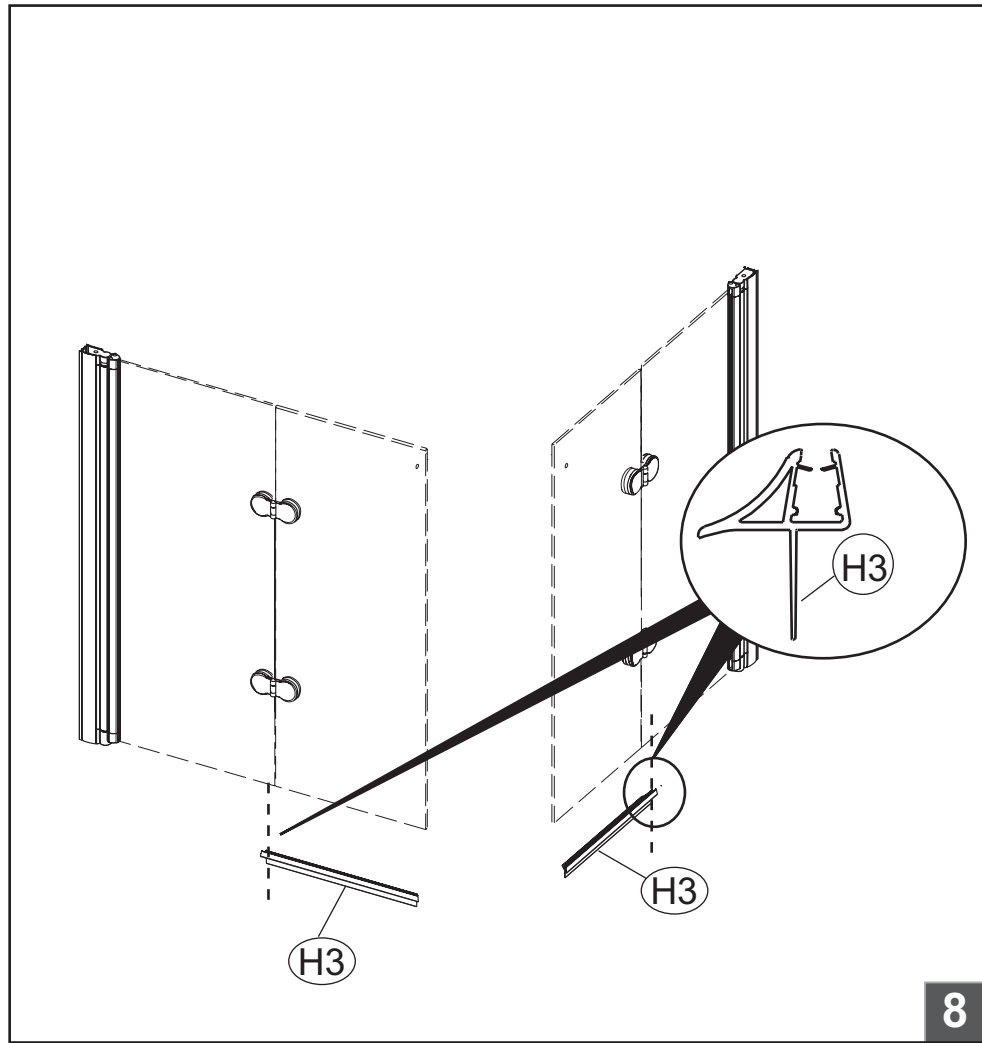

8

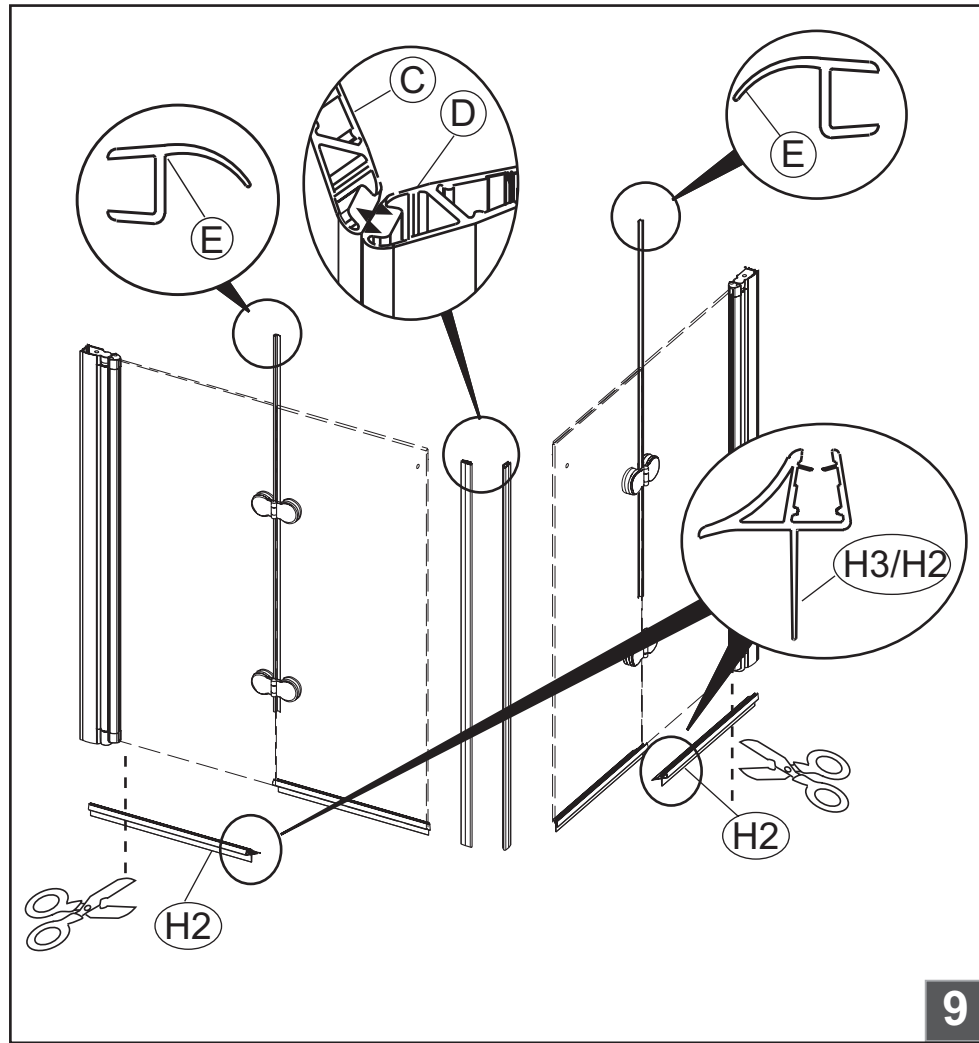

9

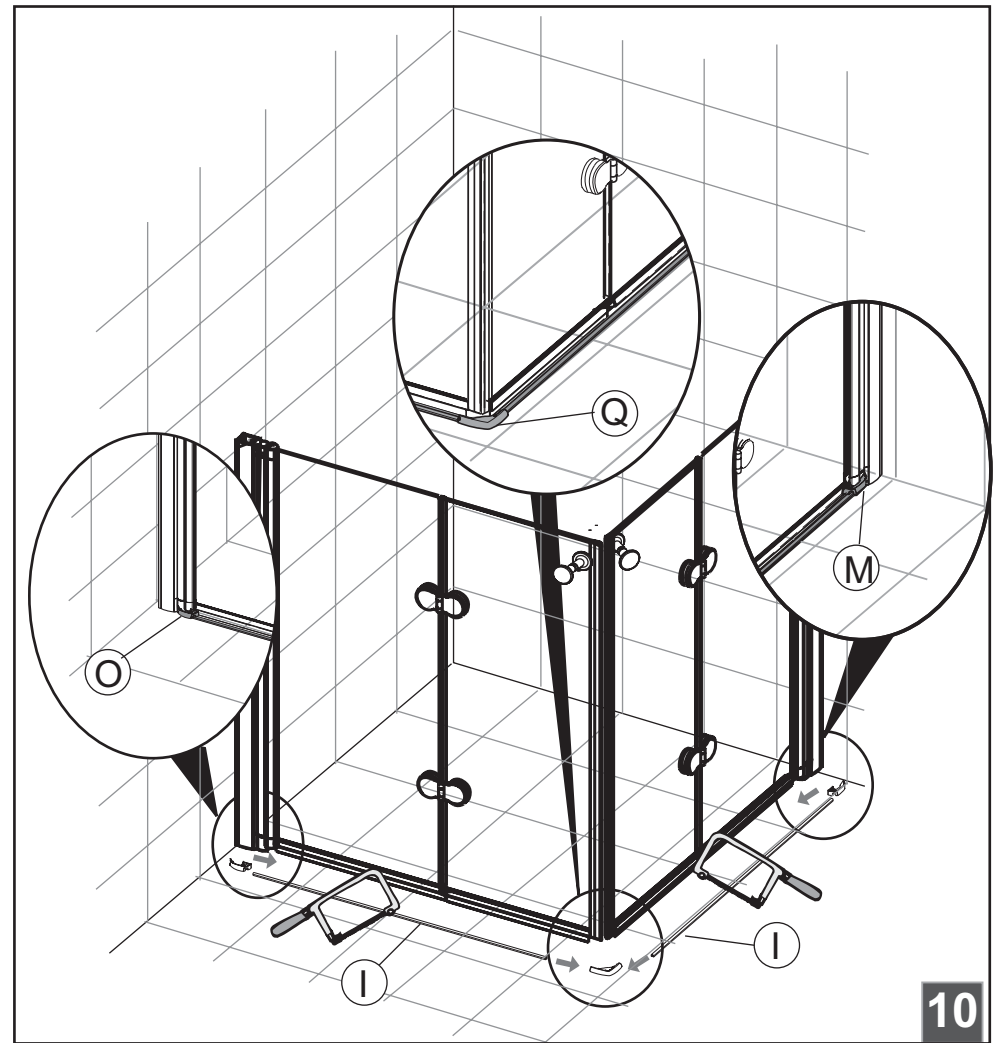

10

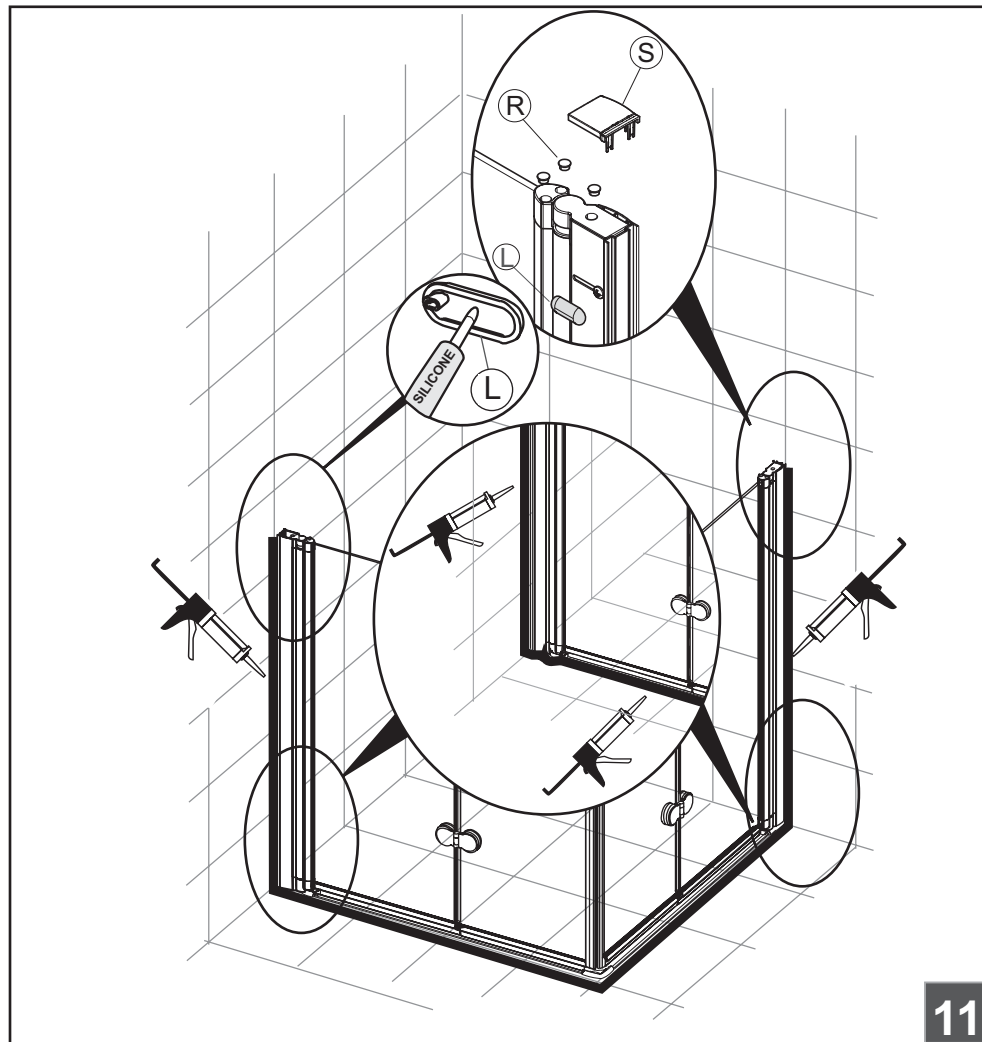

11

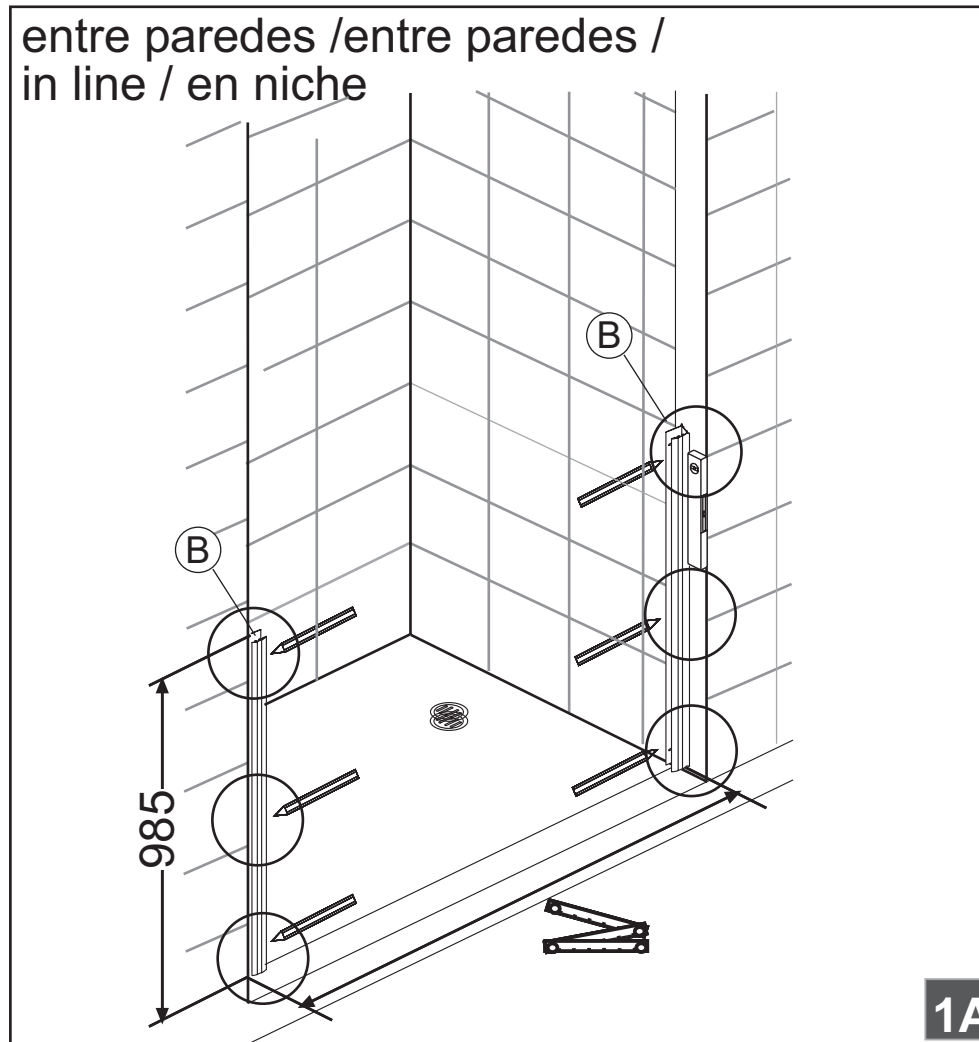

1A

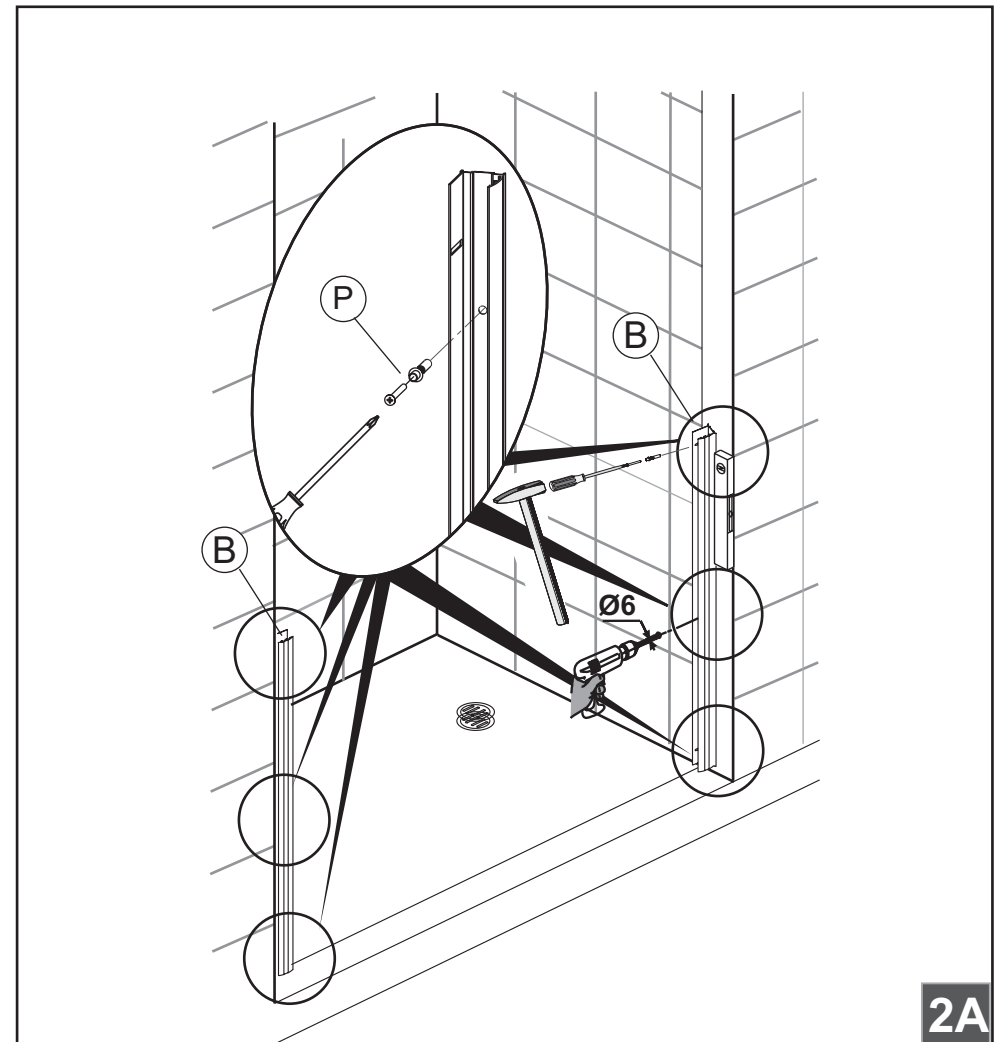

2A

